

De Dietrich

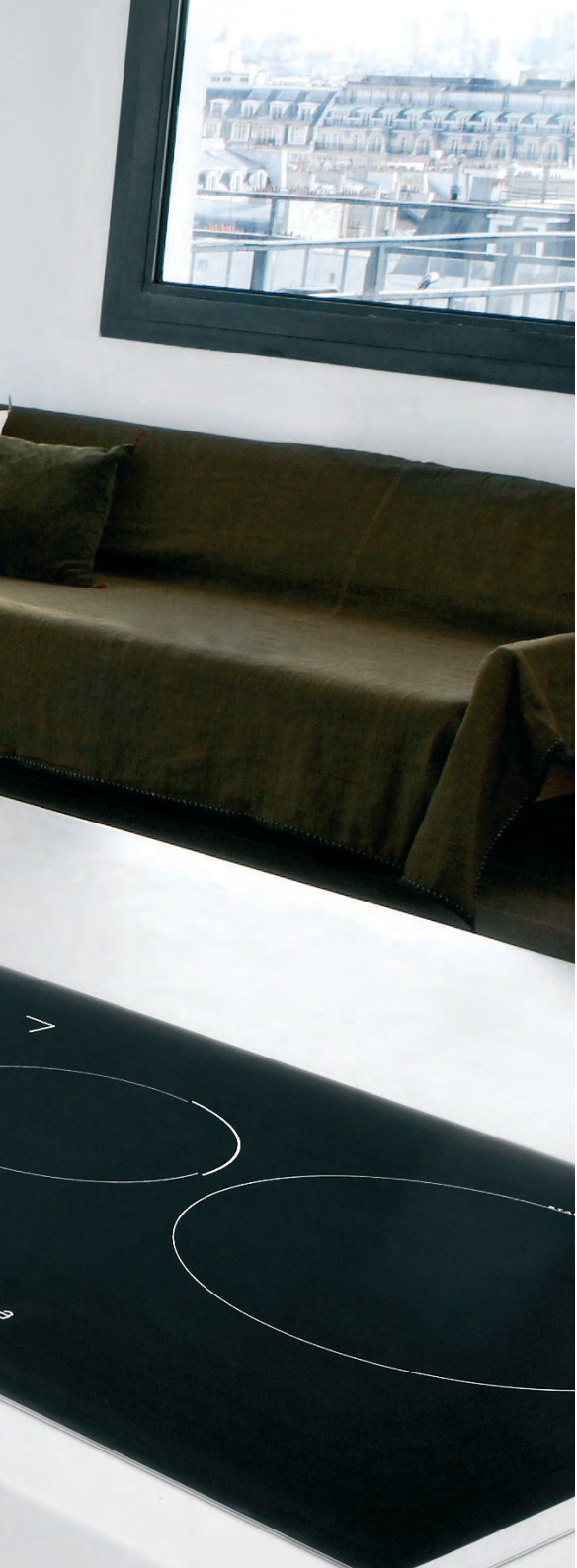





introduction

Setting New Values

As a Master of Innovations, De Dietrich is a brand that is always ahead of its time, constantly developing solutions for the future to enhance your lifestyle. Strong technological know-how, coupled with a heritage of more than 300 years of excellence and passion originating in France, have allowed De Dietrich to achieve today's internationally celebrated status.

New art of environmentally friendly living

As a market leader in Europe, De Dietrich is fully committed to the protection of the environment, particularly in the conservation of raw materials, water and electricity. And furthermore, De Dietrich cooking, washing and cooling appliances are A-Class energy efficient.

The power of innovation

Since the initial experimental launch of electronic ovens in 1977, various innovations have come to life, to reward investment made in research and development. De Dietrich, the inventor of the pyrolysis ovens, induction hobs and many other firsts, has constantly launched many developments throughout the range in washing, cooking and cooling: from steam ovens to bigger induction zones; development of ICS technology in cooking and dishwashing, gas hob with touch controls or the first colour matrices ovens in the market.

In line with its innovative vocation and its forefront position in domestic appliances design, De Dietrich always offers you the best.

oven colour matrices pyrolitic

DOP790XS
Stainless Steel



ICS technology



oven multifunction plus pyrolitic

DOP760XS
Stainless Steel



ICS technology



Multifunction Plus Oven - Pyrolitic 60cm

- > Pyro-Turbo cleaning system
- > Sapphire blue back-lit Intelligent Touch Colour Matrics programmer
- > Axiom panel
- > ICS function - 12 pre-programmed dishes
- > Cooking guide - 50 recipes
- > Low temperature cooking - 8 pre-programmed dishes
- > Extra-safe Cool door "A Class" with 4 layers of glass
- > 9 cooking functions - including bread programme
- > Biogrill® Plus: grill comes on automatically - 4 power levels
- > Automatic warning and cleaning Pyrocontrol® Plus
- > Enameled - 53 litre Capacity
- > Pyrolitic Enamelled Wire Side Racks
- > Eolyse® function: fume filter

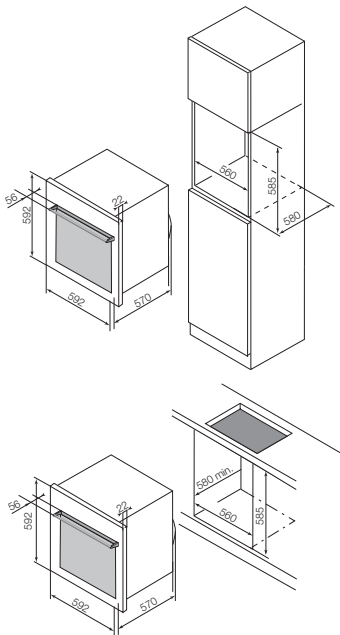

Multifunction Plus Oven - Pyrolitic 60cm

- > Pyro-Turbo Cleaning System
- > Axiom panel
- > Soft touch controls with sapphire blue backlight
- > ICS function - 12 pre-programmed dishes
- > Extra-safe Cool door "A Class" with 4 layers of glass
- > 9 cooking functions - including bread programme
- > Biogrill® - 4 power levels
- > Automatic cleaning Pyrocontrol®.
- > Enameled- 53 litre Capacity
- > Pyrolitic Enamelled Wire Side Racks
- > Eolyse® Function: fume filter

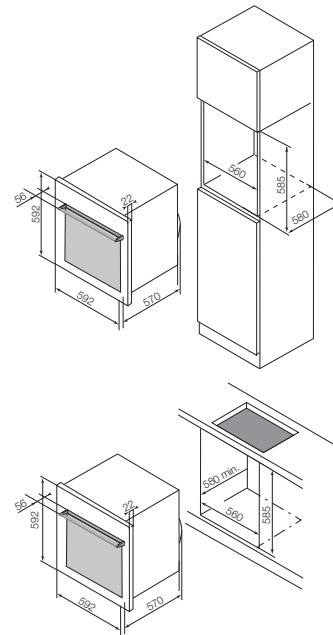

oven multifunction plus pyrolitic

DOP740XS
Stainless Steel



oven multifunction plus

DOE740XS
Stainless Steel



Multifunction Plus Oven - Pyrolitic 60cm

- > Pyro-Turbo cleaning system
- > Soft touch controls with sapphire blue backlight
- > Extra-safe Cool door "A Class" with 4 layers of glass
- > 9 cooking functions - including bread programme
- > Biogrill® - 4 power levels
- > Enameled - 53 litre Capacity
- > Pyrolitic Enameled Wire Side Racks

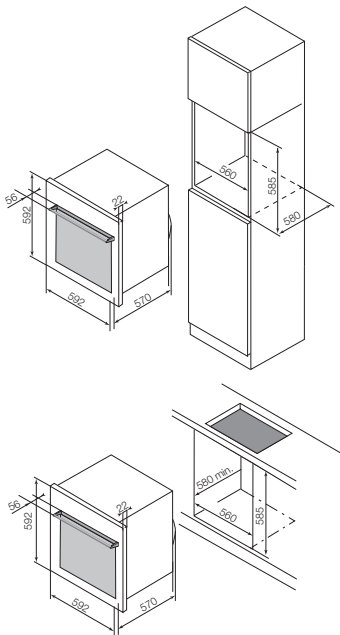

Multifunction Plus Oven 60cm

- > New Top Slide enamel easy cleaning
- > Soft touch controls with sapphire blue backlight
- > Safety door with double glass
- > 9 cooking functions - including bread programme
- > Biogrill® - 4 power levels
- > Enameled - 53 litre Capacity
- > Enamelled Wire Side Racks

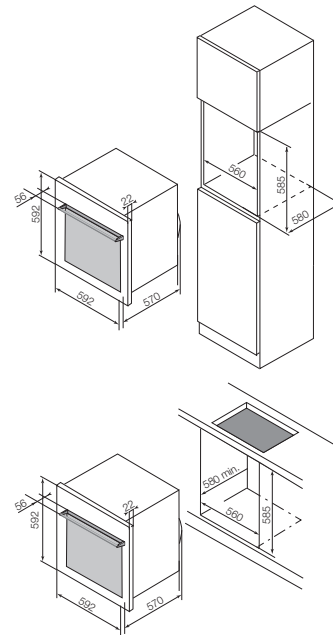

ovens collection 45



DME795XS

Stainless Steel



Fully Built-in Combination Microwave Oven

- > 40 litre Capacity
- > Soft Touch Controls with sapphire blue backlight
- > Automatic cooking function - 10 pre-programmed dishes
- > Microwave power: 1,000W with Quattro System
- > Fan 1,600W
- > Grill power 1,750W - 3 levels
- > Enameled Steel Cavity
- > 4 cooking functions (2 of them combined functions):
 - Grill + Microwave/ Fan + Microwave
- > 2 cooking levels
- > 3 pre-programmed functions
- > Speed defrost
- > 60 minute timer - delayed start function

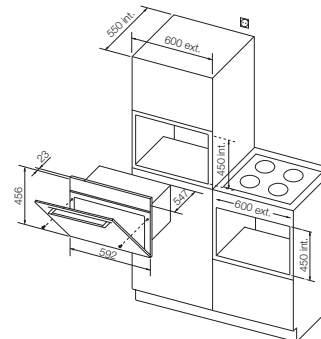

ovens collection 45

DME785X

Stainless Steel



DOV745X

Stainless Steel



Built-in Solo Microwave

- > 40 litre Capacity
- > Soft Touch Controls with sapphire blue backlight
- > Microwave power 1,000W with Quattro System
- > Enameled Steel Cavity
- > 2 cooking levels
- > 3 pre-programmed functions
- > Speed defrost
- > 60 minutes timer - delayed start function

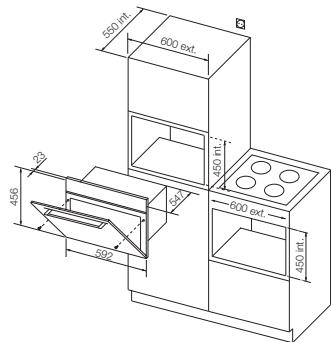

Built-In Steam Oven

- > 23 litre Capacity
- > Soft Touch Controls with sapphire blue backlight
- > Stainless steel interior with removable water reservoir - 1 litre

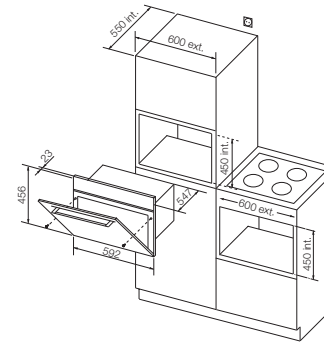

ovens collection 38

DOP799XS
Stainless Steel



DME799X
Stainless Steel



Integrated Multifunction Plus Oven - Pyrolytic

- > 32 litre Capacity
- > Pyro cleaning - 3 cycles
- > Intelligent Touch Controls with Sapphire blue backlight
- > Sapphire blue back-lit Intelligent Touch Programmer
- > Extra-safe Cool door "A Class" with 4 layers of glass
- > 7 cooking functions
- > Biogrill® - 4 power levels
- > Enameled Steel Cavity
- > Pyrolytic Enameled Wire Side Racks

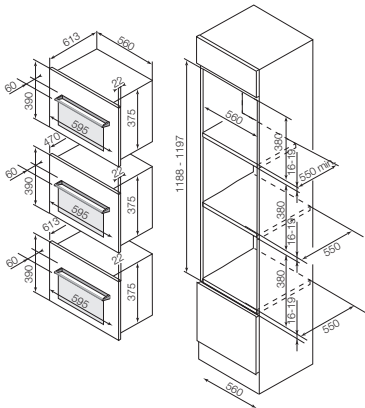

Fully Integrated Combination Microwave Oven

- > 32 litre Capacity
- > Intelligent Touch Controls with sapphire blue backlight
- > Sapphire blue back-lit Intelligent Touch Programmer
- > Microwave power: 1,000W
- > Grill power 1,500W
- > 8 cooking functions
- > Stainless Steel Cavity

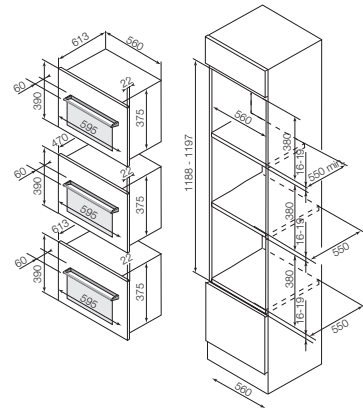

ovens collection 38

DME788X
Stainless Steel



DOV738X
Stainless Steel



Built-in Solo Microwave

- > 32 litre Capacity
- > Intelligent Touch Controls with sapphire blue backlight
- > Sapphire blue back-lit Intelligent Touch Programmer
- > Microwave power: 1,000W
- > 6 cooking functions
- > Stainless Steel Cavity

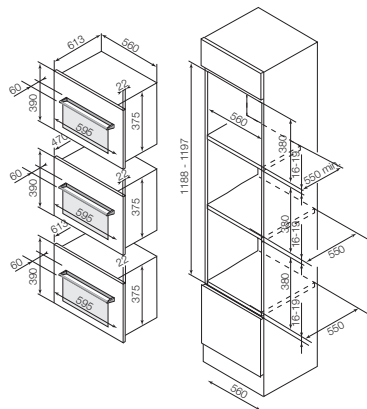

Built-in Steam Oven

- > 23 litre Capacity
- > Intelligent Touch Controls with sapphire blue backlight
- > Sapphire blue back-lit Intelligent Touch Programmer
- > Stainless steel interior with removable water reservoir - 1 litre

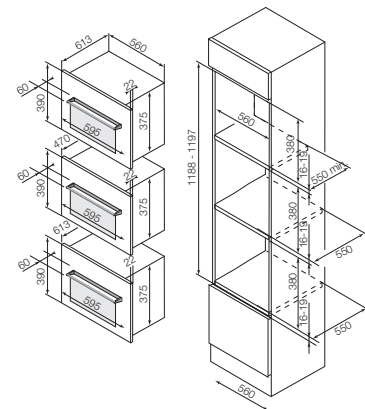

oven multifunction plus

DOE900X
Stainless Steel



Oven 90cm. Multifunction Plus

- > New Top Slide enamel easy cleaning
- > Sapphire blue back-lit Intelligent Touch programmer
- > Safety door with triple glass
- > 10 cooking functions - including bread programme
- > 72 litre Capacity
- > Interior Wire Side Racks

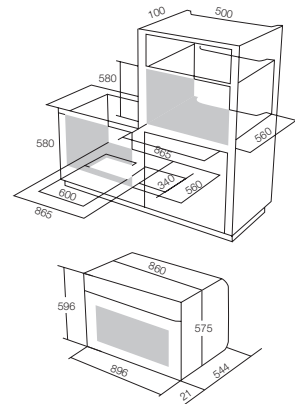

microwave built-in

DME729X
Stainless Steel



Built-in Microwave with Grill

- > Height: 39cm
- > 26 litre Capacity
- > Electronic programmer
- > Microwave power: 900W with Quattro system
- > Halogen Quartz Grill 1,200W - 3 levels
- > Stainless Steel Cavity
- > 6 power levels
- > 3 pre-programmed functions
- > 60 minutes timer - delayed start function

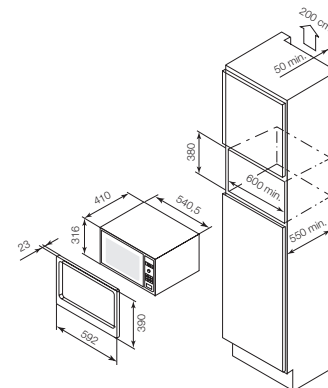

coffee machine built-in espresso

DED700X
Stainless Steel

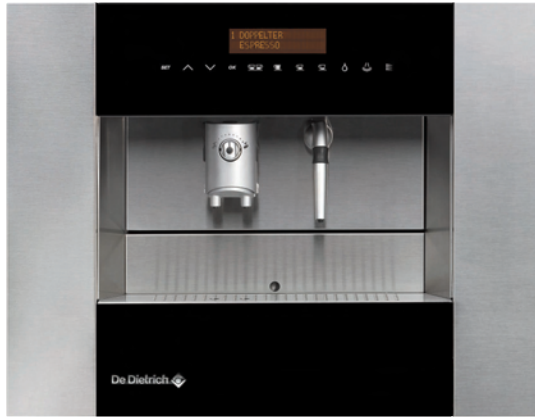

Built-in Espresso Coffee Machine

- > Stainless Steel Front
- > Sapphire blue back-lit Intelligent Touch Programmer
- > Completely automatic functioning
- > Adjustable precision of fineness of coffee grind, quantity of water per cup, quantity of coffee ground, temperature
- > 3 options: Espresso/ Normal Coffee/Long Coffee
- > Simultaneous preparation for up to 2 cups
- > Steam function
- > Water tank - 2 litres
- > Coffee beans reservoir - 300 g
- > Pump pressure - 15 bar
- > Compartment for used coffee grounds

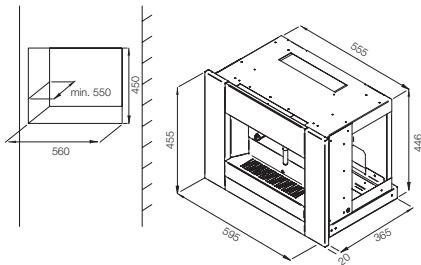

warming drawer

DWD714X
Stainless Steel



Warming Drawer

- > Height: 14cm
- > Capacity: 24L. 20 large dishes, 30 bowls or 80 small coffee cups
- > Fan heating
- > Thermostat knob control: Adjustable temperature from 30°C to 70°C
- > 90 minutes timer
- > "Quadro" rail system for automatic closing
- > Anti-slide removable felt mat drawer liner

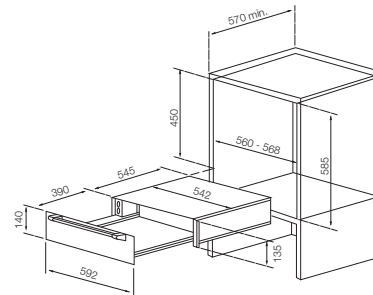

hobs induction



DTI749X
Stainless Steel Frame



93cm Induction hob with Continuum

- > 5 independent zones with 1 Continuum
 - Left: 400mm X 230mm 4.6kW
 - Center: D280mm 4.6kW
 - Rear Right: D160mm 2.2kW
 - Front Right: D230mm 3.2kW
- > 5 boosters
- > Total hob power - 11,800W
- > Intelligent Touch Control with 15 power levels per zone
- > 3 programmable direct access levels per zone
- > 5 x 99 minutes independent timers
- > Safety functions

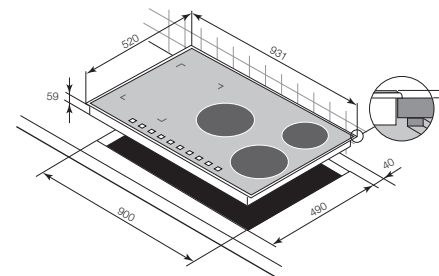

hobs induction

DTI743X

Stainless Steel Frame

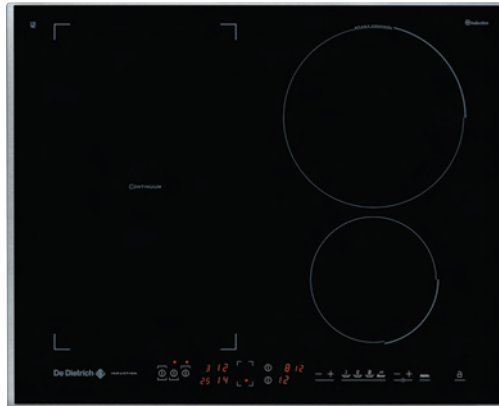

DTI716X

Stainless Steel Frame



65cm Induction hob with Continuum

- > 4 independent zones with 1 Continuum

Left:	400mm x 230mm	4.6kW
Rear Right:	D230mm	3.2kW
Front Right:	D160mm	2.2kW
- > 4 boosters
- > Total hob power - 7,200W
- > Intelligent Touch Control with 15 power levels per zone
- > 3 programmable direct access levels per zone
- > 4 x 99 minutes independent timers
- > Safety functions

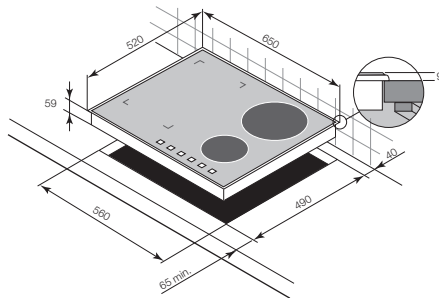

65cm Induction hob

- > 3 independent zones with 1 zone

Front Left:	D 210mm	3.1kW
Rear Left:	D160mm	2kW
Right:	D280mm	2.8kW
- > 3 boosters
- > Total hob power - 5,900W
- > Intelligent Touch Control with 15 power levels per zone
- > 3 programmable direct access levels per zone
- > 3 x 99 minutes independent timers
- > Safety functions

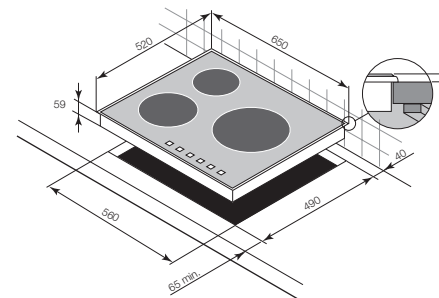

hob vitroceramic

DTV724X
Stainless Steel Frame

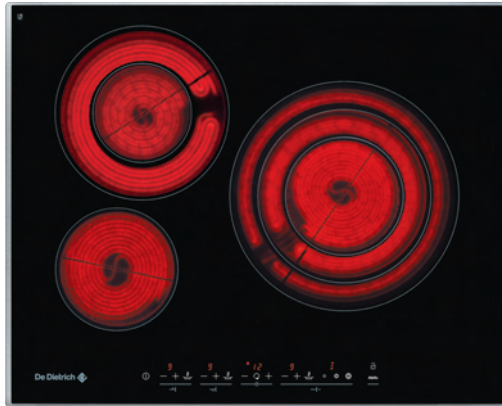

hob gas

DTG775X
Stainless Steel Frame



65cm Vitroceramic Hob

- > 3 Speedring zones with 1 triple crown zone 28cm

Front Left:	D1 65mm	1.2kW
Rear Left:	D140mm/230mm	0.75kW/2.2kW
Right:	D165mm/230mm/300mm	2.7kW/1.95kW/1.05kW
- > Total hob power - 6,100W
- > Intelligent Touch Control with 17 power levels per zone
- > 2 direct access levels per zone
- > 3 x 99 minutes independent timers
- > Safety functions

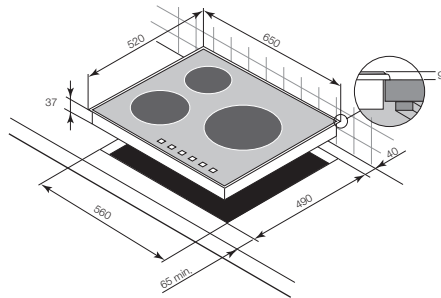

72cm Built-in Gas Hob

- > 5 zones with 1 triple crown zone 3,800W

Left:	3.8kW
Center Rear:	1.75kW
Center Front:	1kW
Rear Right:	3kW
Front Right:	1.75kW
- > Total gas power - 11,300W
- > Front knob control
- > Integrated ignition
- > Stainless Steel control panel
- > Cast iron pan supports
- > Gas safety cut off - Thermocouple security

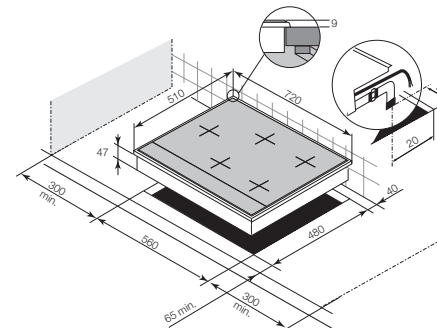

hobs modular

DTI731X
Stainless Steel Frame



DTI741X
Stainless Steel Frame

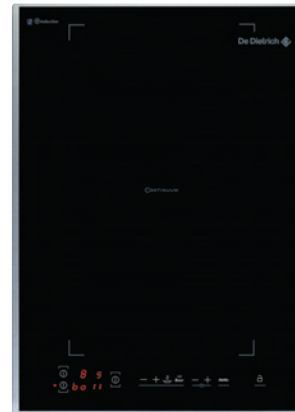

DTI732X
Stainless Steel Frame



38cm Induction Hob

- > 1 zone 28cm 4,600W
- > 1 booster
- > Intelligent Touch Control with 15 power levels
- > 3 direct access levels
- > 1 x 99 minutes independent timer
- > Safety functions

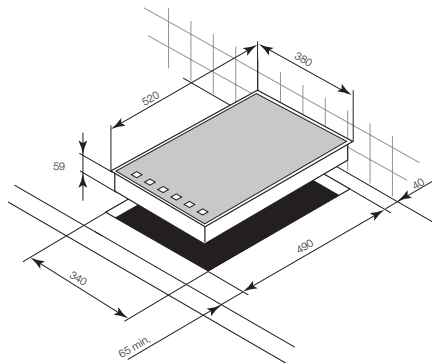

38cm Continuum Induction Hob

- > 1 Continuum zoneless 40x23cm, 4,600W
- > 1 booster
- > Intelligent Touch Control with 15 power levels
- > 3 direct access levels
- > 2 x 99 minutes independent timers
- > Safety functions

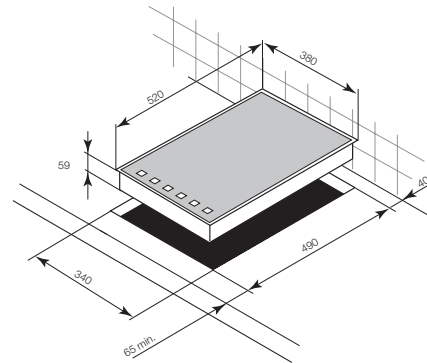

38cm Wok Induction Hob

- 1 Wok zone 3,000W
- 1 booster
- Intelligent Touch control with 9 power levels
- 1 direct access level
- 1 x 99 minutes independent timer
- Safety functions
- **Supplied with Wok**

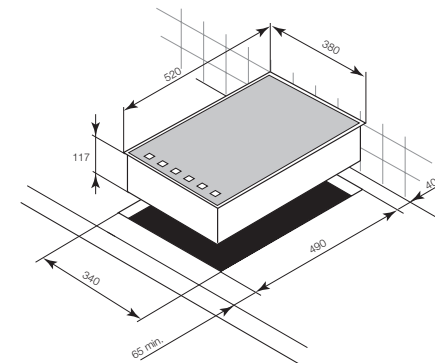

hobs modular

DTG738X
Stainless Steel Frame



ICS technology

DTG708X
Stainless Steel Frame



ICS technology

DTE768X
Stainless Steel Frame



38cm Gas Hob

- > 2 zones with ICS function and touch control including 1 triple crown zone 3,600W
- > Intelligent Touch Control with 9 power levels per zone
- > 2 direct access levels per zone
- > 2 x 99 minutes independent timers
- > Cast iron pan supports
- > Safety functions including immediate Thermocouple safety cut-off
- > Automatic reignition

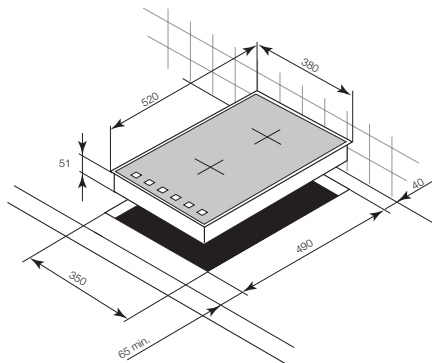

38cm Gas Hob

- > 1 triple crown zone with ICS function and touch control 6,000W
- > Intelligent Touch Control with 9 power levels and 2 direct access
- > 1 x 99 minutes independent timer
- > Cast iron pan supports
- > Safety functions including immediate Thermocouple safety cut-off
- > Automatic reignition
- > **Wok Stand included**

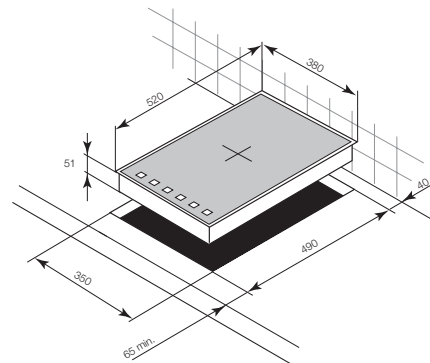

38cm Teppan Yaki

- > Total power - 2,500W
- > Front knob control
- > Power on and residual heat indicators

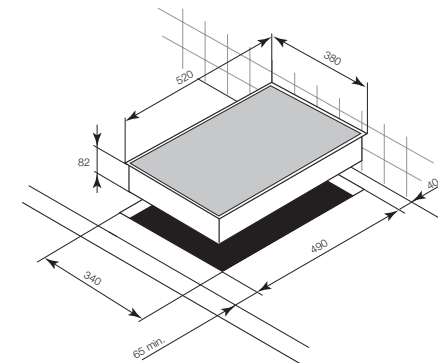

hobs modular

DTE758X
Stainless Steel Frame



38cm Deep Fryer

- > Total power - 2,200W
- > Front knob controls
- > 1 x 15 minutes mechanical timer
- > Safety thermostat
- > Power on indicator
- > Oil capacity - 3.6 litres
- > **Delivered with Stainless Steel cover**

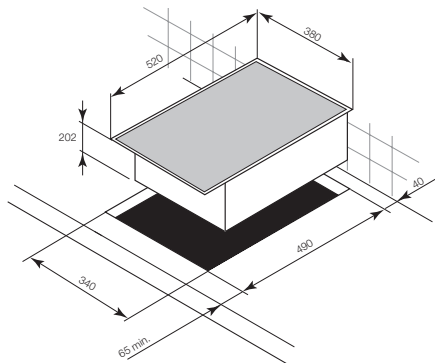

DTE728X
Stainless Steel Frame

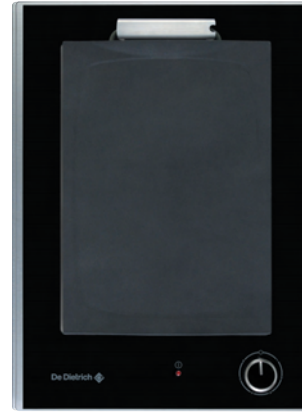

38cm Plancha

- > Total power - 2,500W
- > Front knob control - 7 temperature settings
- > Lava Stone for effective absorption of grease and cooking fumes
- > Removable grill pan
- > Power on indicator

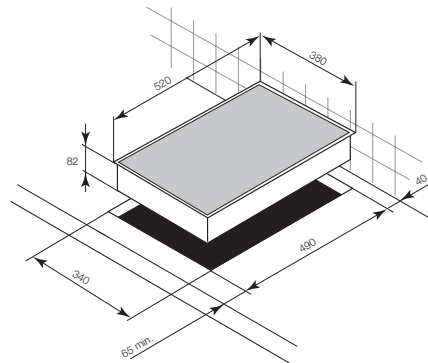

DTE748X
Stainless Steel Frame



38cm Grill

- > Total power - 2,500W
- > Front knob control - 7 temperature settings
- > Removable Stainless Steel Grid
- > Lava Stones for effective absorption of grease and cooking fumes
- > Power on indicator

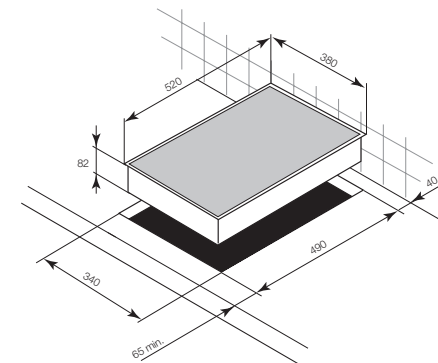

hoods decorative chimney

DHD7000X
Stainless Steel



DHD791X
Stainless Steel



90cm Downdraft hood

- > Extraction power: 900m³/h free outlet
- > Automatic stop
- > Dishwasher safe stainless steel filter
- > Carbon filters provided

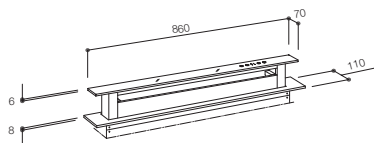
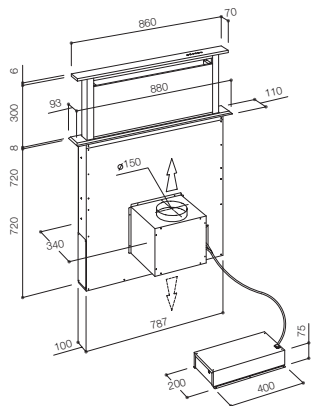

90cm Wall-mounted decorative chimney with peripheral suction surface

- > Extraction power: 900m³/h free outlet
- > Peripheral suction technology
- > Intelligent Touch Electronic Controls - 4 suction speeds
- > Halogen Lighting - 2 x 20W lamps
- > Automatic stop
- > Filter saturation indicator
- > Dishwasher safe stainless steel anti-grease filter
- > Carbon filters included
- > For a free outlet installation, request stainless steel chimney RHD91X

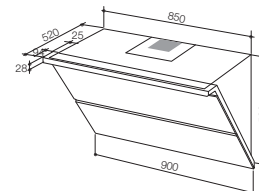
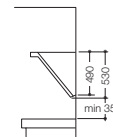

hoods decorative chimney

DHD772X
Stainless Steel



90cm Wall-mounted decorative chimney with peripheral suction surface

- > Extraction power: 800m³/h free outlet
- > Electronic Control - 3 suction speeds
- > Peripheral suction technology
- > Halogen lighting - 3 x 20W lamps
- > Automatic stop
- > Filter saturation indicator

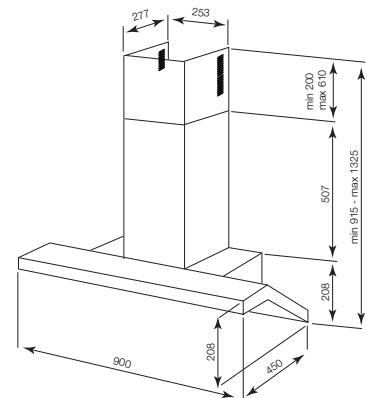

DHD796X
Stainless Steel



90cm Wall-mounted decorative chimney

- > Extraction power: 850m³/h free outlet
- > Intelligent Touch Electronic Control - 3 suction speeds + 1 intensive speed
- > Color lighting changes according to suction speeds: (1st: blue, 2nd: orange and 3rd: red)
- > Halogen lighting - 2 x 20W lamps
- > Automatic stop
- > Filter saturation indicator
- > Dishwasher safe stainless steel filters

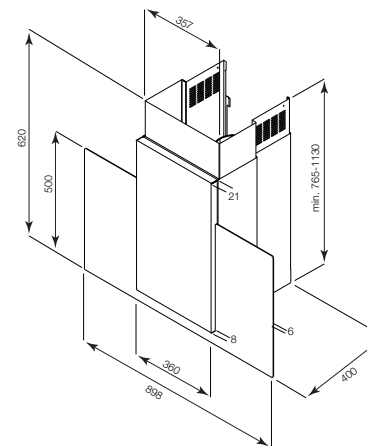

hoods decorative chimney

DHD787X
Stainless Steel



90cm Wall-mounted decorative chimney

- > Extraction power: 1,100m³/h free outlet
- > "Silence" system - reduction of noises
- > Intelligent Touch Electronic Control - 4 extraction speeds + 1 intensive speed
- > Adjustable Halogen lighting - 2 x 20W lamps
- > Automatic stop
- > Filter saturation indicator
- > Dishwasher safe stainless steel filters

hood telescopic chimney

DHT496XP1
Stainless Steel



90cm Telescopic Hood

- > Extraction power: 900m³/h free outlet
- > Electronics Control - 14 power levels
- > Halogen lighting - 2 x 20W lamps
- > Dishwasher safe stainless steel filters

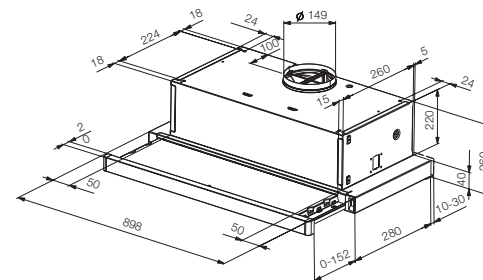
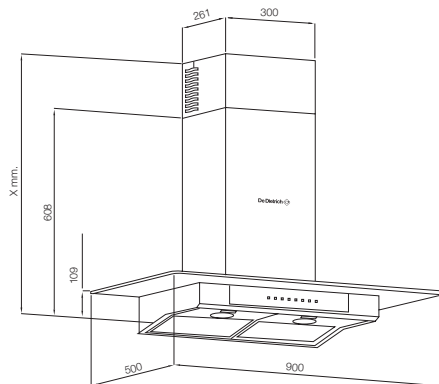

hoods decorative island

DHD493XE1
Stainless Steel



120cm Decorative island hood

- > Extraction power - 1,000m³/h
- > Electronic Control - 3 suction speeds + 1 intensive speed
- > Halogen Lighting - 4 x 20W lamps
- > Automatic stop
- > Dishwasher safe stainless steel filters

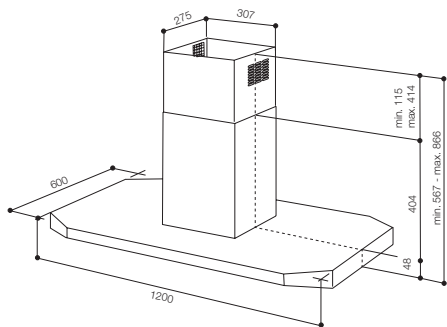

DHD585XE1
Stainless Steel



+ remote control

36cm Cylinder decorative island hood

- > Extraction power - 900 m³/h
- > Electronic Control - remote control with 4 suction speeds
- > Halogen lighting - 1 x 50W lamp
- > Automatic stop
- > Dishwasher safe stainless steel filters

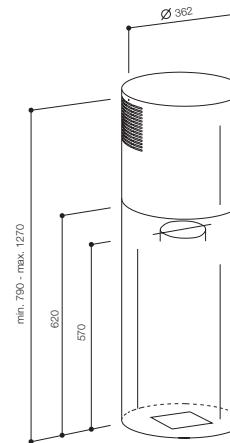

dishwasher quattro

DQF754XE1

QUATTRO
Total Stainless Steel



ICS technology



AAA class

60cm Free-standing dishwasher 2 independent washing areas

- > Place settings - 1 to 12
- > AAA Class (Energy/Washing/Drying)
- > Silence inside: 44 db
- > Interior Lighting with electroluminescent technology
- ICS technology: detects the load level and degree of dirtiness and adjusts the wash cycle automatically, giving an optimal final result.**
- > Programming:
 - Primo mode: 7 programmes/6 temperatures + ICS
 - Secundo mode: 7 programmes/6 temperatures + ICS
 - Tertio mode: 7 programmes/6 temperatures + ICS
 - Quattro mode: 2 programmes in 3 combinations
- > LCD display
- > Touch Control panel
- > 4-in-1 automatic function
- > Delayed start up to 24 hours
- > Turbo ventilation drying with Eolyse function
- > Stainless steel filter
- > AquaBlock total safety: Anti-overflow / Anti-leak / Anti-flood pipe / Electrical water intake cut-off
- > Upper and Bottom baskets in 3 different areas:
 - Racks for dishes and glasses
 - Foldable racks for high glasses and cups
 - Multiposition cutlery holders
- > Consumption: 14L/1.05kWh/180min

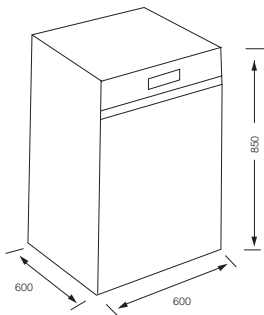

dishwasher free-standing

DVF742XE1

Stainless Steel



ICS technology



AAA class

60cm Free-standing dishwasher

- > Place setting: 1 to 12
- > AAA Class (Energy/Washing/Drying)
- > Silence inside: 45 db
- > Interior lighting with electroluminescent technology
- > 7 programmes including 1 ICS technology
- > 6 temperatures
- > Front LCD display
- > Touch Control panel
- > 4-in-1 automatic function
- > Delayed start up to 12 hours
- > Aquasafe+ total safety: Anti-overflow / Anti-leak / Anti-flood pipe / Electrical water intake cut-off
- > Condensation drying
- > Stainless steel filter
- > Adjustable interior
- > Adjustable Espace upper basket
- > Foldable racks for mugs
- > Consumption: 15L/1,05kWh/150min

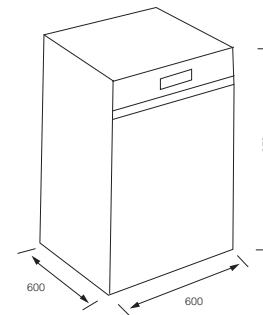

dishwasher built-in

DVH640JE1

ICS technology



AAA class



60cm Fully-Integrated dishwasher

- > Place settings - 1 to 12
- > AAA Class (Energy / Washing / Drying)
- > Silence inside: 43 db
- > Interior lighting with electroluminescent technology
- > 7 programmes including 1 ICS technology
- > 7 temperatures
- > Touch Control on door edge with LCD display
- > 4-in-1 automatic function
- > Delayed start up to 24 hours
- > AquaBlock total safety: Anti-overflow / Anti-leak / Anti-flood pipe / Electrical water intake cut-off
- > Turbo ventilation drying with Eolyse function
- > Stainless steel filter
- > Spot light
- > Adjustable interior
- > Adjustable Espace upper basket
- > Foldable racks for mugs
- > Consumption: 12L/1.05kWh/145min

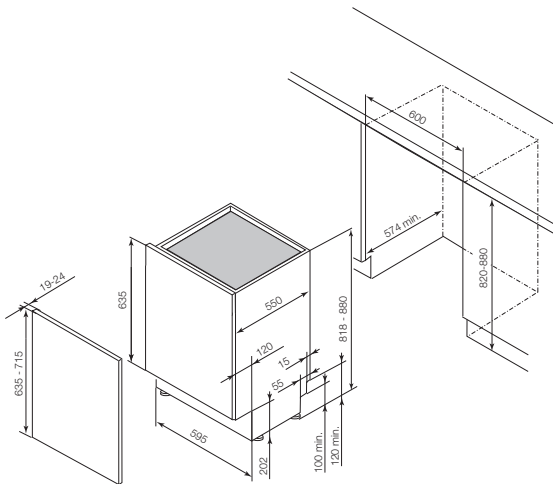

washing machine free-standing

DFW812X

Stainless Steel



A+ class

Free-standing washing machine

- > Spin speed: 1,200 rpm
- > Washing capacity: 8kg
- > Energy Class A+, Washing Class A
- > ICS Automatic mode:
 - White/Color Selection
 - Selection of degree of dirtiness
- > Manual mode:
 - 16 programmes: Delicates/Intensive Pre-wash/Quick wash /Normal cotton/Cold wash/Wool/Mix
 - 1 temperature and programme Knob control
- > Multifunction LCD display:
 - Washing cycle indicator
 - Total time remaining digital indicator
 - Clock and End of Program
- > Reduced Noise level: acoustic isolation
- > Safety:
 - Aquabloc/Anti-over flood/ Portal opening/ Foam suppression
- > Consumption: 59L / 1.36 kWh.

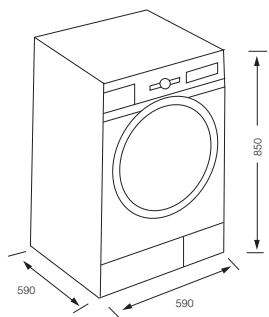

refrigerator harmony pro style set



PSS300
Total Stainless Steel



Combi Side by Side 3 doors

- > Total net capacity: 570 litres
- > Energy class A+
- > Freezer NO FROST
- > Electronic Temperature Control
- > Combi Side by Side 3 doors: Refrigerator + Freezer + Wine Chiller
- > Full Anti Fingerprints Stainless Steel Doors

Refrigerator:

- > Net capacity: 330 litres
- > Uniform Cooling
- > 1 transparent vegetable drawer
- > 1 glass vegetable drawer shelf
- > Audible and Visual Door Open alarm

Freezer 4*:

- > Net capacity: 78 litres
- > Uniform cooling: NO FROST
- > Audible and Visual temperature alarm
- > 4 transparent drawers and 1 ice tray
- > Super Freeze

Wine Chiller:

- > Net capacity: 162 litres
- > 39 bottles
- > Wooden shelves
- > Adjustable temperature: 6°C - 16°C

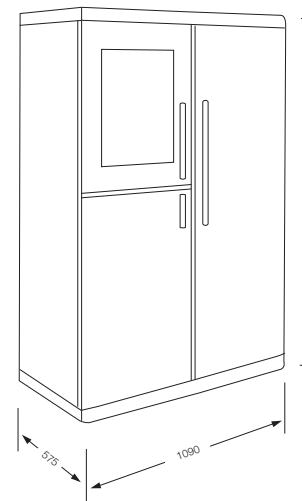

refrigerator side by side

DKA866X

Stainless Steel Door



A⁺class



Side by Side

- > Total net capacity: 504 litres
- > Energy class A+
- > Uniform cooling: NO FROST
- > Electronic Temperature control
- > Cool Box: Independent temperature drawer
- > Full Anti Fingerprints Stainless Steel Doors

Refrigerator:

- > Net capacity: 334 litres
- > Transparent vegetable drawer with ventilation
- > Bottle rack
- > Audible and Visual Door Open alarm
- > Super cooling

Freezer 4*:

- > Net capacity: 170 litres
- > Audible and Visual temperature alarm
- > Water and Ice Automatic dispenser
- > 2 drawers
- > Super freezing

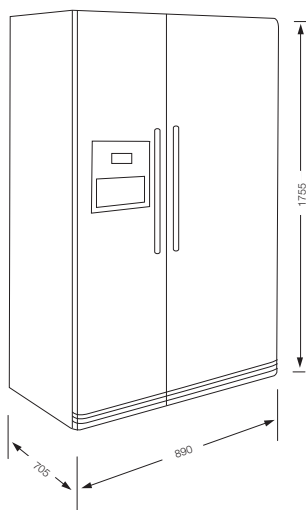

refrigerator combi

DKP837X

Stainless Steel



A⁺class

2.01m Combi

- > Total net capacity: 315 litres
- > Energy Class A+
- > ICS Technology
- > Independent NO FROST
- > Multilingual Touch Control LCD display
- > "Easy open" side handle

Refrigerator:

- > Net capacity: 249 litres
- > Uniform Cooling: No Frost
- > Vacuum Box
- > Audible and Visual Door Open alarm
- > Shelves and glass bottle rack
- > Multilevel Neon lighting

Freezer 4*:

- > Net capacity: 66 litres
- > Uniform cooling: No Frost
- > Audible and Visual temperature alarm
- > 3 drawers
- > 1 freezing tray + 2 integrated ice trays
- > Super Freeze

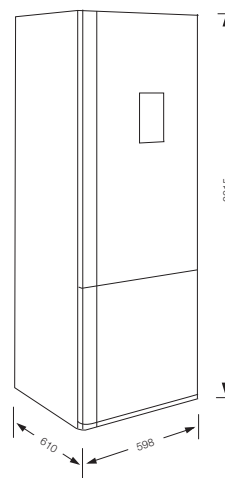

wine chiller built-in



DWS850X
Stainless Steel

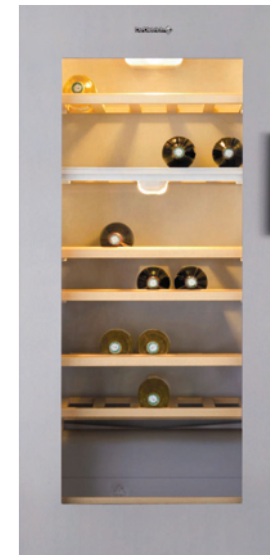

1.22m Built-in Wine Chiller

- > 1.225m Recess
- > Total with gross capacity: 220 litres
- > 64 bottles
- > Full Glass and Stainless Steel Door
- > Wooden shelves
- > Electronic Thermostat with 2 independent zones
 - Cold zone (6°C - 11°C)
 - Long storage (12°C - 18°C)
- > LCD display

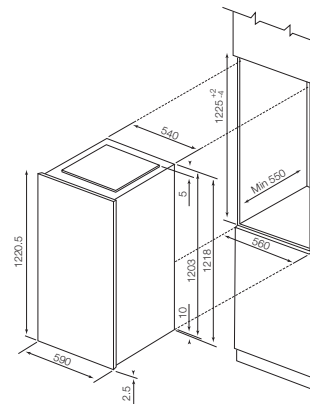





• De Dietrich Malaysia, a division of Fagor Home Appliances (M) Sdn Bhd, reserves the right to modify its products in order to conform with technological and product development. • Details of specifications and accessories are subject to change to suit local conditions and requirements. • Product range and specifications pictured in this catalogue may vary from product models available locally. • Appliances body and accessory colours might differ slightly from the printed photos in this catalogue. • De Dietrich Malaysia shall not be held liable for any typographical or printing errors. All specification are for reference only.

notes:

SETTING NEW VALUES

FagorBrandt SAS

7, rue Henri Becquerel, 92854 Rueil-Malmaison Cedex, France. Tel: 33 (0)1 47 16 68 00 Fax: 33 (0)1 47 16 68 97

Fagor Home Appliances (M) Sdn Bhd

Lot 9 - Unit B2, Natco Industrial Park, Lorong Keluli 1B, Seksyen 7, Perindustrian Bukit Raja Selatan, 40000 Shah Alam, Selangor.
Tel: +603-3341 9966 Fax: +603-3343 2799 Website: www.de-dietrich.my iCare: 1-300-88-5188